

**8) PLATE RACK - 5 SHELF.**

**S.NO.8-First floor**

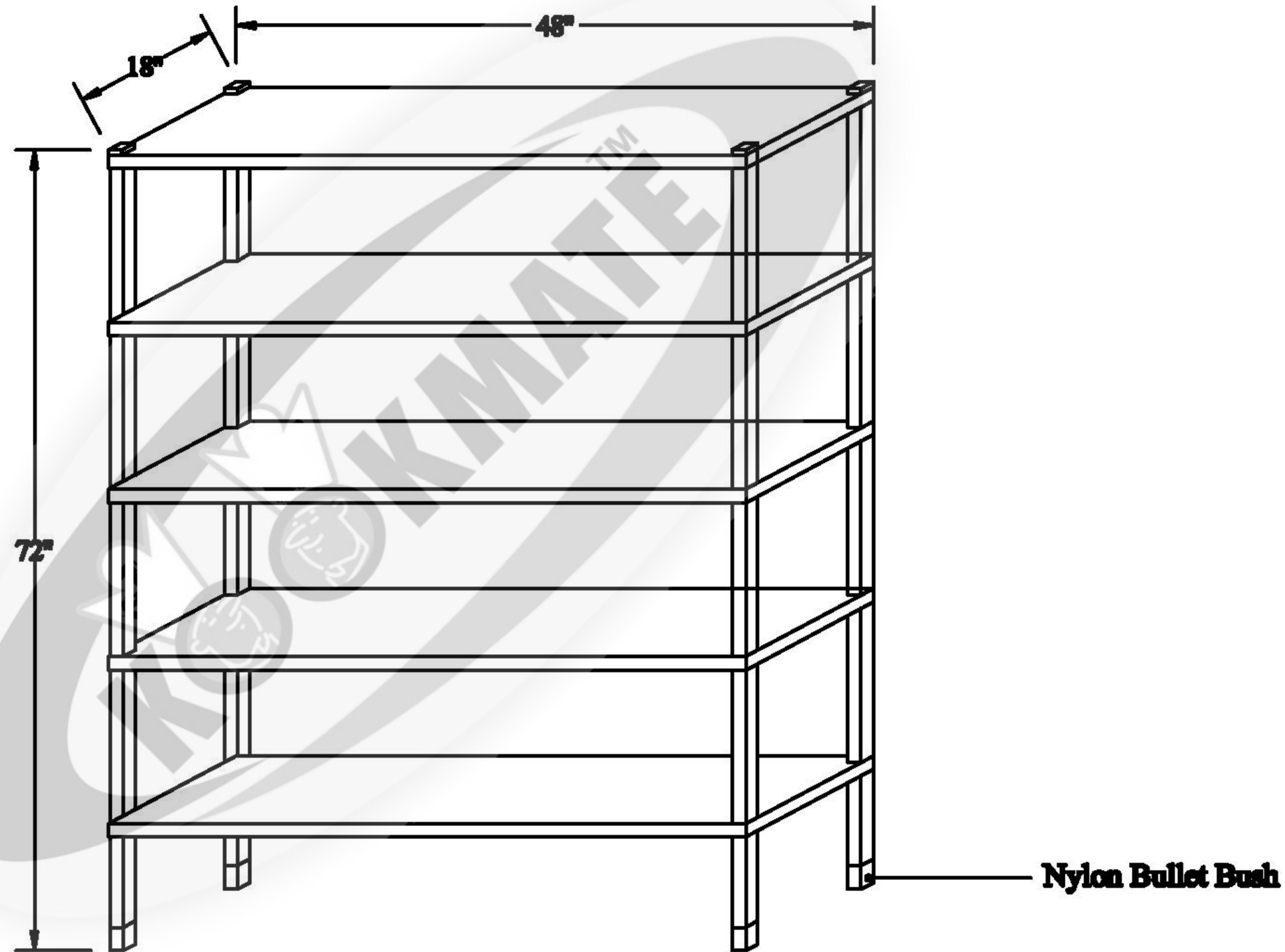

**Note :**

All Dimensions Are In Inches.

Equipment over all size :

**Preview :**

**CLIENT :**

**DRAWING TITLE:**

**KITCHEN EQUIPMENT DRAWING**

<b>Date:</b>	<b>Desit:</b>	<b>Checked:</b>
<b>Scale</b>	<b>Rev Date</b>	
<b>DWG NO:</b>	<b>001</b>	

**Designed By :**

**Drawn By : AND**

**ACES**  
SINCE 1972  
**AIR CONTROL EQUIPMENTS & SYSTEMS.**  
E-mail : [aces.office.admin@gmail.com](mailto:aces.office.admin@gmail.com)

**AIR CONTROL EQUIPMENT&SYSTEMS.**  
NO-25,VASUDEVAPURAM STREET,  
WEST MAMBALAM,  
CHENNAI-33.  
PH.NO-04424806060